

REDUCERS



ALUMINIZED OD - ID REDUCER

Reduces larger I.D. pipe to smaller O.D. pipe.

P/N	OD - ID	LENGTH
8663	1 5/8" - 1 1/2"	4"
8661	1 7/8" - 1 3/4"	4 1/2"
8650	2" - 1 1/2"	4 1/2"
8651	2" - 1 5/8"	4"
8902	2" - 1 3/4"	5 3/4"
8652	2" - 1 7/8"	5 1/8"
8653	2 1/4" - 1 3/4"	5"
8938	2 1/4" - 2"	4"
8941	2 1/2" - 2"	4"
8654	2 1/2" - 2"	9 1/2"
8942	2 1/2" - 2 1/4"	4"
8655	2 1/2" - 2 1/4"	9 1/2"
9600	3" - 2 1/2"	6 1/4"
9334	3" - 2 3/4"	6"
9333	3 1/2" - 3"	6"
9722	4" - 3"	6"
9332	4" - 3 1/2"	6"
9331	5" - 4"	6"
9723	5" - 4 1/2"	6"
8969	6" - 5"	6"



ALUMINIZED ID - OD REDUCER

Reduces larger O.D. pipe to smaller I.D. pipe.

P/N	ID - OD	LENGTH
8925	1 1/2" - 1 3/8"	4"
8926	1 5/8" - 1 1/2"	4"
8927	1 3/4" - 1 1/2"	4"
8928	1 3/4" - 1 5/8"	4"
8929	1 7/8" - 1 1/2"	4"
8935	1 7/8" - 1 3/4"	4 1/2"
8936	2" - 1 3/4"	4 1/2"
8930	2" - 1 13/16"	4"
8660	2" - 1 7/8"	4"
8909	2 1/8" - 2"	5 3/4"
8931	2 1/4" - 1 7/8"	4"
8911	2 1/4" - 2"	5 3/4"
8932	2 1/4" - 2 1/8"	4"
8913	2 1/2" - 2"	5 3/4"
8940	2 1/2" - 2 1/4"	4 1/2"
8959	2 3/4" - 2 1/2"	6"
8960	3" - 2 1/2"	6"
8961	3" - 2 3/4"	6"
8962	3 1/2" - 3"	6"
8963	4" - 3"	6"
8964	4" - 3 1/2"	6"
8965	5" - 4"	6"
9336	6" - 5"	6"



ALUMINIZED ID - ID REDUCER

Reduces O.D. pipes of different sizes.

P/N	ID - ID	LENGTH
8921	1 1/4" - 1 1/2"	4"
8920	1 5/8" - 1 1/2"	4"
8922	2" - 1 1/2"	4"
8923	2" - 1 5/8"	4"
8944	2" - 1 3/4"	4 1/2"
8945	2" - 1 7/8"	4 1/2"
8924	2 1/8" - 2"	4"
8946	2 1/4" - 2"	4 1/2"
8947	2 1/2" - 2"	4 1/2"
8948	2 1/2" - 2 1/4"	4 1/2"
8952	2 3/4" - 2 1/2"	6"
8953	3" - 2 1/2"	6"
8954	3" - 2 3/4"	6"
8955	3 1/2" - 3"	6"
8956	4" - 3"	6"
8957	4" - 3 1/2"	8"
8958	5" - 4"	8"
9721	5" - 4 1/2"	6"
9335	6" - 5"	8"



ALUMINIZED OD - OD REDUCER

Reduces larger O.D. pipe to smaller I.D. pipe.

P/N	OD - OD	LENGTH
8904	2" - 1 13/16"	5 3/4"
8908	2 1/8" - 2"	7 1/4"
8657	2 1/4" - 2"	4"
8912	2 1/4" - 2"	5 3/4"
8658	2 1/2" - 2"	9 1/2"
8659	2 1/2" - 2 1/4"	9 1/2"
9648	4" - 3"	8"
9649	5" - 4"	8"
9720	6" - 4"	6"
9650	6" - 5"	8"

REDUCER BUSHINGS



ALUMINIZED SPLIT REDUCER BUSHINGS

Reduces I.D. of a muffler by 1/8" without increasing its overall length. Made of 16 gauge steel.

P/N	REDUCES FROM - TO
1A	3" - 2 7/8"
2	2 3/4" - 2 5/8"
3	2 5/8" - 2 1/2"
5	2 1/2" - 2 3/8"
6	2 3/8" - 2 1/4"
7	2 1/4" - 2 1/8"

P/N	REDUCES FROM - TO
8	2 1/8" - 2"
9	2" - 1 7/8"
10	1 7/8" - 1 3/4"
11	1 3/4" - 1 5/8"
12	1 5/8" - 1 1/2"

CONNECTORS



ALUMINIZED ID - ID CONNECTOR

Connects O.D. pipes of the same size.

P/N	ID - ID	LENGTH
8916	1 1/2" - 1 1/2"	4"
23075	1 1/2" - 1 1/2"	18"
8949	1 3/4" - 1 3/4"	4 1/2"
23076	1 3/4" - 1 3/4"	18"
8917	1 7/8" - 1 7/8"	4"
23077	1 7/8" - 1 7/8"	18"
14337	2" - 2"	4"
23078	2" - 2"	18"
8950	2 1/8" - 2 1/8"	4 1/2"
8951	2 1/4" - 2 1/4"	4 1/2"
23079	2 1/4" - 2 1/4"	18"
14338	2 1/2" - 2 1/2"	4"
23080	2 1/2" - 2 1/2"	18"
8980	2 3/4" - 2 3/4"	4"
13025	2 3/4" - 2 3/4"	12"
14339	3" - 3"	4"
14601	3" - 3"	6"
13026	3" - 3"	12"
14340	3 1/2" - 3 1/2"	4"
14602	3 1/2" - 3 1/2"	6"
13027	3 1/2" - 3 1/2"	12"
14341	4" - 4"	4"
14603	4" - 4"	6"
13028	4" - 4"	12"
14605	5" - 5"	6"
8974	6" - 6"	6"



ALUMINIZED ID - OD CONNECTOR

Connects I.D. and O.D. pipes of the same size.

P/N	ID - OD	LENGTH
8662	1 1/2" - 1 1/2"	4 7/8"
13001	1 1/2" - 1 1/2"	12"
23001	1 1/2" - 1 1/2"	18"
23051	1 1/2" - 1 1/2"	24"
33001	1 1/2" - 1 1/2"	36"
13002	1 5/8" - 1 5/8"	12"
23002	1 5/8" - 1 5/8"	18"
8934	1 3/4" - 1 3/4"	4 1/2"
13003	1 3/4" - 1 3/4"	12"
23003	1 3/4" - 1 3/4"	18"
23052	1 3/4" - 1 3/4"	24"
33002	1 3/4" - 1 3/4"	36"
8937	1 7/8" - 1 7/8"	4 1/2"
13004	1 7/8" - 1 7/8"	12"
23004	1 7/8" - 1 7/8"	18"
23053	1 7/8" - 1 7/8"	24"
33003	1 7/8" - 1 7/8"	36"
8933	2" - 2"	5 3/4"
8906	2" - 2"	7 1/4"
13005	2" - 2"	12"
23005	2" - 2"	18"
23054	2" - 2"	24"
33004	2" - 2"	36"
8914	2 1/8" - 2 1/8"	4"
13006	2 1/8" - 2 1/8"	12"
23006	2 1/8" - 2 1/8"	18"
23055	2 1/8" - 2 1/8"	24"
33005	2 1/8" - 2 1/8"	36"

P/N	ID - OD	LENGTH
8939	2 1/4" - 2 1/4"	4 1/2"
8915	2 1/4" - 2 1/4"	9 1/2"
13007	2 1/4" - 2 1/4"	12"
23007	2 1/4" - 2 1/4"	18"
23056	2 1/4" - 2 1/4"	24"
33006	2 1/4" - 2 1/4"	36"
8943	2 1/2" - 2 1/2"	4 1/2"
13008	2 1/2" - 2 1/2"	12"
23008	2 1/2" - 2 1/2"	18"
23057	2 1/2" - 2 1/2"	24"
33007	2 1/2" - 2 1/2"	36"
8975	3" - 3"	6"
13009	3" - 3"	12"
23009	3" - 3"	18"
23058	3" - 3"	24"
33008	3" - 3"	36"
8976	3 1/2" - 3 1/2"	6"
13010	3 1/2" - 3 1/2"	12"
9599	3 1/2" - 3 1/2"	18"
8991	4" - 4"	6"
13011	4" - 4"	12"
23010	4" - 4"	18"
23059	4" - 4"	24"
8978	5" - 5"	6"
13012	5" - 5"	12"
24712	5" - 5"	18"
23060	5" - 5"	24"
8979	6" - 6"	6"

CONNECTERS

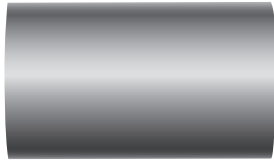

ALUMINIZED OD - OD CONNECTOR

Connects I.D. pipes
of the same size.

P/N	OD - OD	LENGTH
8907	2" - 2"	5 ¾"
8918	2 ¼" - 2 ¼"	6"
8919	2 ½" - 2 ½"	4 ½"
8970	3" - 3"	6"
8971	3 ½" - 3 ½"	6"
8972	4" - 4"	8"
8973	5" - 5"	8"

ALUMINIZED TILT CAB CONNECTORS TOP

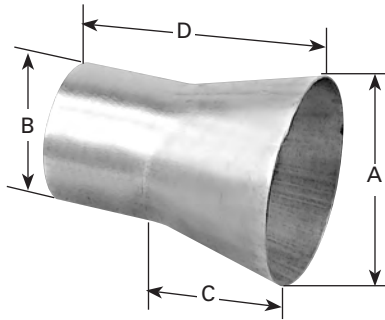

P/N	A	B	C	D
9341	5 ¾" OD	4" OD	2 ½"	7"
9342	6 ¾" OD	5" OD	2 ½"	7 ⅝"

ALUMINIZED TILT CAB CONNECTORS BOTTOM

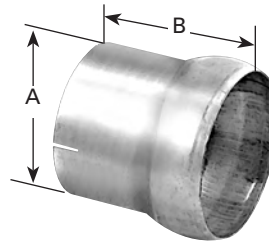

P/N	A	B
9343	4" ID	4 ½"
9344	5" ID	5 ⅝"

ADAPTERS

THREADED ADAPTERS



P/N	OD SIZE	THREAD(NPT)	LENGTH
9514	3"	3"	6"
9516	3 ½"	3 ½"	6"
9518	4"	4"	6"

NPT - National Pipe Thread

ADAPTERS

FLARED ADAPTERS

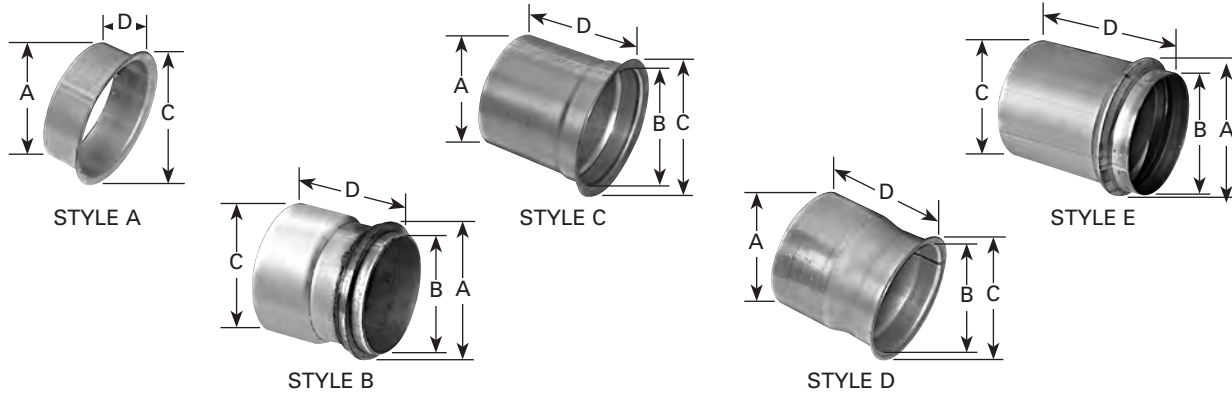

P/N	STYLE	A (O.D.)	B (I.D.)	C (O.D.)	D (LGTH.)	FLARE IN DEG.	APPLICATION	USE W/ V-BAND CLAMP
9705	D	3.970	2.850	3.780	3.867	20		9395
9706	D	3.977	2.836	3.970	3.482	20		9398
9707	A	2.500	3.345	3.695	1.532	20		9395
9390	A	NA	NA	NA	NA	20	FORD MOTOR CO, DETROIT DIESEL 6V71, 7V73, CUMMINS V555, V902	NA
9470	C	3.005	3.028	3.618	4.181	22	DETROIT DIESEL 6V71	9395
9708	A	3.005	2.869	3.541	3.568	45		NA
9471	C	3.005	3.040	3.775	4.522	45		9395
9479	A	3.183	3.015	3.915	2.200	20	GMC TRUCK/BUS W/ 8.2N	9611
9709	A	3.512	3.385	4.071	4.176	22	CAT 3208T	9611
9710	A	3.350	3.373	4.025	5.018	45	DETROIT DIESEL 6V71	9622
9392	C	3.525	3.505	4.320	6.095	45		9396
9473	C	3.490	3.630	4.165	4.035	22	DETROIT DIESEL 8V-71	9613
9711	C	3.520	3.620	4.270	4.100	22	DETROIT DIESEL 8V-72	9396
9712	C	3.480	3.670	4.212	4.140	22	DETROIT DIESEL 8V-73	9613
9391	A	3.010	2.865	3.905	1.310	20	DETROIT DIESEL 8V92, 4-53	9611
9713	D	3.990	3.605	4.260	4.050	22	DETROIT DIESEL 8V-71	9613
9476	C	NA	NA	NA	NA	22	DETROIT DIESEL 12V71	NA
9472	D	3.960	3.550	4.305	3.868	22	DETROIT DIESEL 8.2N, CUMMINS VT225	9396
9714	C	4.005	3.975	4.500	5.922	45		NA
9474	A	3.950	3.850	4.535	1.810	22	DETROIT DIESEL 6-71, 8.2N, 8.2T, MACK	NA
9475	A	3.985	3.875	4.540	5.170	45	CUMMINS	NA
9715	B	5.13	4.250	4.800	1.940	20	DETROIT DIESEL 8V-71T, 16V-71T, 6V-92T, 8V-92T	NA
9393	A	5.005	4.880	5.475	6.275	45	CUMMINS	NA
9478	A	5.035	4.870	5.720	3.025	22	CATERPILLAR TURBO, CUMMINS TURBO, INTERNATIONAL	9616
9716	A	4.990	4.825	5.572	5.608	20	INTERNATIONAL	NA
9717	A	5.010	4.885	5.845	6.287	20	T-50 TURBO CHARGER	9616
9394	C	NA	NA	NA	NA	45	T-50 TURBO CHARGER	NA
9718	B	5.150	4.215	4.780	2.045	20	DETROIT DIESEL 8V-71T, 16V-71, 6V-92T, 8B-92T, 16V-92T	NA
9719	E	5.658	4.825	4.998	6.168	NA	CUMMINS ENGINES	9615

▲ WITH MACHINED RING